

and rear as practicable. The segments do not need to be continuous if the sum of the length of all segments is at least half of the length of the trailer and these segments are evenly spaced. The segments shall be mounted between 15 inches and 60 inches above the road surface or as close as practicable to this area. **2F**

The rear of each trailer and semitrailer must be equipped with reflective sheeting. Each strip of reflective sheeting shall be positioned as horizontally as practicable, extending across the full width of the trailer, beginning and ending as close to the extreme edges as practicable. The segments shall be mounted between 15 inches and 60 inches above the road surface or as close as practicable to this area. **2G**

Two pairs of white strips of reflective sheeting, each pair consisting of 12 inch strips, must be positioned horizontally and vertically onto the right and left upper corners of the rear of the body of each trailer and semitrailer, as close as practicable to the top of the trailer and as far apart as practicable. If the perimeter of the body is not square or rectangular, the strips may be applied along the perimeter, as close as practicable to the uppermost and outermost areas of the rear of the body on the left and right sides. **2H**

**TURN SIGNAL AND STOP LAMPS\*** are required on all automobiles and commercial vehicles. (2C)

**MARKER LAMPS** are required on vehicles or combinations exceeding 30 feet in length; one on each side near the front of the vehicle and one each side near the rear, not less than 24 inches above the roadway; white or amber in the front and red in the rear, each visible for a distance of 500 feet to the side. (1A) Clearance lamps that are visible at 90 degree angles to the right and left sides, respectively, may also serve as marker lamps, provided that an additional marker lamp, white or amber, is displayed approximately midway between the front and rear clearance lamps. (1B) Identification lights

are required on the front of truck-tractors and rear of semi-trailers exceeding 80 inches in width, and both the front and rear of trucks and buses exceeding 80 inches in width. (2E)

**FLASHING LIGHTS** are prohibited, except on an authorized emergency vehicle, school bus, road maintenance equipment, farm tractors, self-propelled farm equipment or any vehicle as a means of indicating a right or left turn or the presence of a vehicular traffic hazard. All flashing warning lights must be the four-way flasher type unless otherwise authorized.

### *General Driving Rules*

Any motor vehicle carrying passengers for hire, any school bus whether carrying passengers or not, or any vehicle carrying explosives or flammable liquid as a cargo must stop upon approaching any railroad crossing, and shall not proceed across the tracks until safe to do so.

The driver of any motor truck when traveling upon a roadway outside of a business or residential district shall not follow within 500 feet of another vehicle except when overtaking or passing.

A non-negotiable copy of the vehicle registration card (cab card) shall be in the immediate possession of the person operating a vehicle and shall be displayed upon demand to any peace officer or other authorized official.

Loads may not project more than three feet beyond the front wheels or front bumper of any vehicle. Loads which extend more than four feet beyond the rear of a vehicle must be marked at the extreme rear with a red light visible from the rear and sides from 500 feet during the hours of darkness; and at other times, with a red, yellow, or orange flag or cloth at least 16 inches square.

For your convenience, the following agencies are located at the

### **Administrative Truck Center 1110 Centre Pointe Curve Mendota Heights, MN 55120**

Questions pertaining to Commercial Vehicle Safety and Inspections:

Minnesota Department of Public Safety  
Minnesota State Patrol--  
Commercial Vehicle Section  
Suite 410  
(651)405-6171

International Registration Plan and  
International Fuel Tax Agreement, prorate and reciprocity:

Minnesota Department of Public Safety  
Driver & Vehicle Services-Prorate Section  
Suite 425  
(651)405-6161

Information on Interstate and Intrastate Commerce and  
Operating Authority, Single State Registration:

Minnesota Department of Transportation  
Motor Carrier Services  
Suite 420  
(651)405-6060

Special Permits (Over dimension, over weight loads,  
twin-trailer routes, etc.)

Minnesota Department of Transportation  
Permit Section  
Suite 420  
(651)405-6000

Questions pertaining to traffic regulations and operation  
of non-commercial vehicles:

Minnesota Department of Public Safety  
Minnesota State Patrol  
444 Cedar Street, Suite 130  
St. Paul, MN 55101  
(651)297-3935

Licensing information (CDL)  
Minnesota Department of Public  
Safety Driver & Vehicle Services  
445 Minnesota Street  
St. Paul, MN 55101  
(651) 297-5029

# Trucks and Trailers

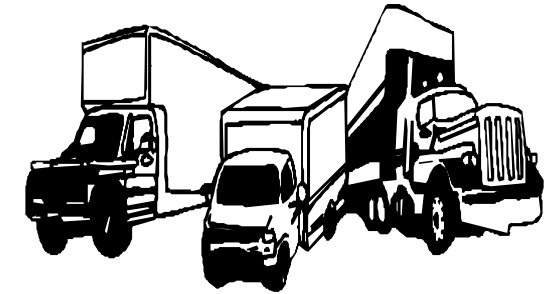

## Required Equipment & Inspections

## Inspections/Equipment

**ANNUAL INSPECTION:** It is unlawful for a person to operate or permit the operation of a commercial vehicle registered in Minnesota unless the vehicle displays a valid safety inspection decal issued by a state certified inspector, or the vehicle carries (1) proof that the vehicle complies with federal motor vehicle inspection standards for vehicles in interstate commerce, and (2) a certificate of compliance issued by the Department of Public Safety. Commercial motor vehicles that require the annual inspection include:

1. single vehicles having a gross vehicle weight greater than 26,000 pounds;
2. each vehicle of a combination having a gross vehicle weight greater than 26,000 pounds;
3. a vehicle used in the transportation of hazardous materials and required to be placarded; or
4. a bus.

Gross vehicle weight is the actual loaded weight of the vehicle or the manufacturer's gross vehicle weight rating, whichever is greater. Inspection decals are valid for period of twelve months, except that farm trucks with a gross weight of less than 57,000 pounds, storage trailers, and building mover vehicles may be issued decals which are valid for two years.

**DAILY INSPECTION REQUIRED:** The driver of a commercial motor vehicle must complete a DAILY INSPECTION REPORT at the COMPLETION of each day's work on each commercial vehicle the driver has operated. A copy of the daily inspection report from the previous day must be carried in the vehicle. The driver must complete a PRE-TRIP inspection at the beginning of each workday. The pre-trip inspection need only be completed in writing if there was no daily inspection report left in the vehicle from the previous day.

**REAR SAFEGUARDS:** With a few exceptions, trucks, trailers, and semi-trailers

having a rear bed or body clearance of more than 30 inches from the ground, must be equipped with a rear protection device so constructed and located so as to prevent another vehicle from penetrating that area immediately below the rear of the truck. Vehicles constructed and maintained so that the body or other parts of the vehicle afford adequate rear end protection need not be equipped with special devices.

**FLAPS:** Trucks, truck tractors, trailers, and semi-trailers, except rear end dump farm trucks and United States military vehicles, must be equipped with flaps behind the rearmost wheels, with ground clearance not more than 1/5 the horizontal distance measured from the center of the rear axle to the flap.

**BRAKES:** Every motor vehicle, other than a motorcycle, must be equipped with brakes adequate to stop and hold such vehicle, including two separate means of applying the brakes, on at least two wheels. In general, trailers and semi-trailers with a gross weight of 3,000 pounds or more must be equipped with brakes adequate to control the movement of and to stop and hold the trailer or semi-trailer. Trailers or semi-trailers with a gross weight of more than 6,000 pounds which are required to have brakes must also be equipped with a breakaway system which allows the brakes to activate automatically should the trailer or semi-trailer become detached from the towing unit. Motor vehicles, trailers and semi-trailers manufactured after June 30, 1988, must be equipped with foot brakes which operate on all wheels.

**EXCEPTIONS:** Vehicles having three or more axles manufactured prior to July 1, 1988, are not required to be equipped with brakes on the front axle if the brakes on the other wheels are adequate to meet performance standards prescribed by state law. (Pursuant to federal rules, this exception does not apply to vehicles manufactured after 1980, which are engaged in interstate

commerce.) A trailer used by a farmer to transport products produced on the user's farm, or supplies back to the farm of the trailer's user may be operated without brake provided the gross weight of the trailer does not exceed 3,000 pounds while towed by a passenger vehicle; or 12,000 pounds when towed by any other vehicle except a self-propelled implement of husbandry. A temporary auxiliary axle attached to a motor vehicle during the period of road restrictions for the purpose of relieving weight on another axle need not be equipped with brakes if the combined weight of the temporary auxiliary axle and the axle to be relieved does not exceed 18,000 pounds.

**HEADLIGHTS** must be depressed when within 1,000 feet of an oncoming vehicle and within 200 feet when following another vehicle. Lighted lamps are required during the period of sunset to sunrise; any time it is raining, snowing, sleeting, or hailing; and at any time when visibility is impaired due to such things as weather, fog, or smoke.

**CLEARANCE LAMPS** are required on every vehicle more than 80 inches in width unladen or with load. Two are mounted in front on opposite sides at least 24 inches above the headlight centers and not more than 6 inches from the outer edge, and two are similarly mounted on the rear. The forward lamps must be amber or white in color and the rear lamps shall be red.(2D)

**LICENSE PLATE** must be lighted and visible from a distance of 50 feet to the rear. It is the duty of the person driving the vehicle to keep the license plate clean, legible, and unobstructed. Covering the license plate with any material, including clear or colorless materials that affect the plate's visibility or reflectivity is prohibited. (2B)

**REAR LAMPS\*:** Two red rear lamps visible from a distance of 500 feet are required. They must be mounted at the same level and spaced as widely as practicable. (2A)

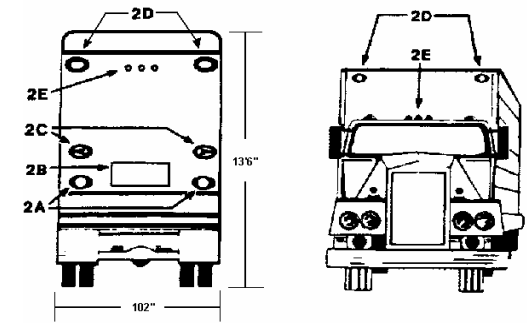

**REFLECTORS\*:** Two red reflectors are required on the rear of the vehicle, not less than 20 nor more than 60 inches above the roadway and spaced as far apart as practicable. Reflectors may be incorporated into the rear lamps of a vehicle. (2A)

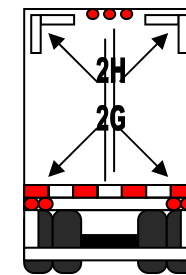

Van Trailer

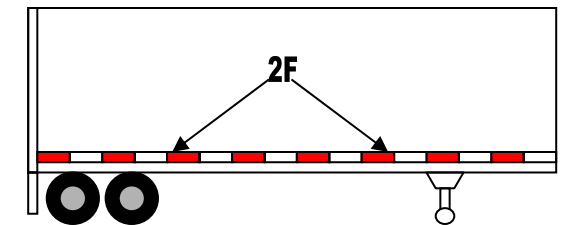

**CONSPICUITY TAPE** (red/white reflective sheeting) is required on all trailers and semitrailers which have an overall width of 80 inches or more.

Along the sides of a trailer or semitrailer, each strip of conspicuity tape shall be positioned as horizontally as practicable, beginnings and ending as close to the front