

CONSPICUITY MARKING (red/white reflective sheeting) is required on all trailers and semitrailers which have an overall width of 80 inches or more and a GVWR > 10,000 lbs.

Along the sides of a trailer or semitrailer, each strip of conspicuity material shall be positioned as horizontally as practicable, beginning and ending as close to the front and rear as practicable. The segments do not need to be continuous if the sum of the length of all segments is at least half of the length of the trailer and these segments are evenly spaced. i.e. a 48 ft. semi-trailer requires a minimum of 24 ft. of conspicuity material. The segments shall be mounted between 15 inches and 60 inches above the road surface or as close as practicable to this area. **2F**

The rear of each trailer and semitrailer must be equipped with reflective sheeting. Each strip of reflective sheeting shall be positioned as horizontally as practicable, extending across the full width of the trailer, beginning and ending as close to the extreme edges as practicable. The segments shall be mounted between 15 inches and 60 inches above the road surface or as close as practicable to this area. **2G** Each trailer manufactured on or after 12/1/1993 and equipped with a rear impact guard must also have reflective sheeting applied to the full width of the rear impact guard. **2H**

Two pairs of white strips of reflective sheeting, each pair consisting of 12 inch strips, must be positioned horizontally and vertically onto the right and left upper corners of the rear of the body of each trailer and semitrailer, as close as practicable to the top of the trailer and as far apart as practicable. If the perimeter of the body is not square or rectangular, the strips may be applied along the perimeter, as close as practicable to the uppermost and outermost areas of the rear of the body on the left and right sides. **2J**

Truck tractors manufactured on or after 7/1/1997 must have a red and white strip on

each wheel flap bracket **2K**, and two L shaped white strips on each side of the rear as close to the top of the body and as far apart as practicable. **2L**

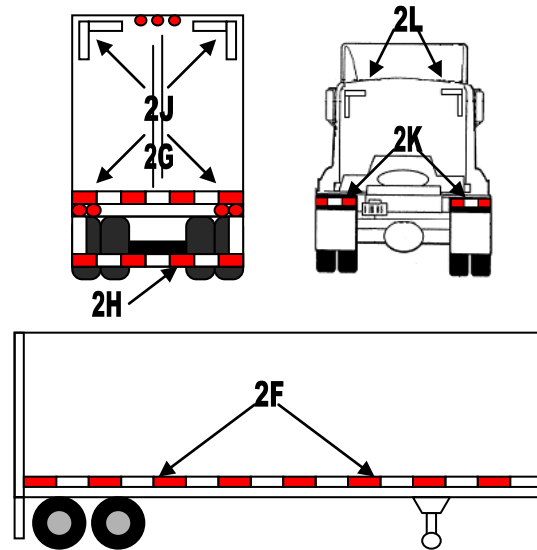

TIRES No vehicle may be operated with a tire tread depth less than 4/32" on any steering axle or less than 2/32" on any non-steering axle.

All tires must be free of any tread or sidewall separation or damage exposing body ply or belt materials. Tires must not be flat (50% or less of the maximum manufacturer's inflation rating) or have any audible leak.

The load on a tire may not exceed the manufacturer's rated weight limits.

**Minnesota State Patrol
Commercial Vehicle Section
1110 Centre Pointe Curve, Suite 410
Mendota Heights, MN 55120
651-350-2000, Option 1
msp.dps.mn.gov**

Other agency phone numbers are listed below.

Information on Interstate and Intrastate Commerce and Operating Authority, Unified Carrier Registration.
Minnesota Department of Transportation
Office of Freight and Commercial Vehicle Operations
(651)215-6330

International Registration Plan and International Fuel Tax Agreement and reciprocity:
Minnesota Department of Public Safety
Driver & Vehicle Services – Prorate Section
(651)205-4141

Special Permits (Over dimension, over weight loads, twin-trailer routes, etc...)
Minnesota Department of Transportation
Permit Section
(651)296-6000

Licensing information (CDL)
Minnesota Department of Public Safety
Driver & Vehicles Services
445 Minnesota Street
St. Paul, MN 55101
(651)296-6911

Trucks and Trailers

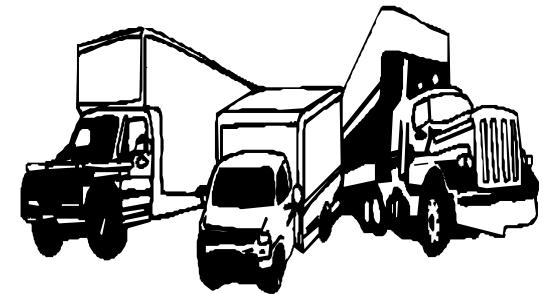

Required Equipment & Inspections

ANNUAL INSPECTION: It is unlawful for a person to operate or permit the operation of a commercial vehicle registered in Minnesota unless the vehicle displays a valid safety inspection decal issued by a state certified inspector, or the vehicle carries (1) proof that the vehicle complies with federal motor vehicle inspection standards for vehicles in interstate commerce, and (2) a certificate of compliance issued by the Department of Public Safety. Commercial motor vehicles that require the annual inspection include:

1. single vehicles having a gross vehicle weight greater than 26,000 pounds;
2. each vehicle of a combination having a combined gross vehicle weight greater than 26,000 pounds;
3. a vehicle used in the transportation of hazardous materials and required to be placarded; or
4. a bus.

Gross vehicle weight is the actual loaded weight of the vehicle or the manufacturer's gross vehicle weight rating, whichever is greater. An inspection decal is valid for 12 months after the month specified on the decal.

DAILY INSPECTION REQUIRED: The driver of a commercial motor vehicle must complete a DAILY INSPECTION REPORT at the COMPLETION of each day's work on each commercial vehicle the driver has operated. A copy of the daily inspection report from the previous day must be carried in the vehicle. The driver must complete a PRE-TRIP inspection at the beginning of each workday. The pre-trip inspection need only be completed in writing if there was no daily inspection report left in the vehicle from the previous day.

REAR IMPACT GUARDS: With a few exceptions, trucks, trailers, and semi-trailers having a rear bed or body clearance of more than 30 inches from the ground, must be equipped with a rear impact guard so constructed and located so as to prevent another vehicle from penetrating that area

immediately below the rear of the vehicle. Trailers and semi-trailers manufactured on or after 1/26/1998 having a rear bed or body clearance of more than 22 inches from the ground, must be equipped with a rear impact guard so constructed and located so as to prevent another vehicle from penetrating that area immediately below the rear of the vehicle. Vehicles constructed and maintained so that the body or other parts of the vehicle afford adequate rear end protection need not be equipped with special devices.

FLAPS: Trucks, truck tractors, trailers, and semi-trailers, except rear end dump farm trucks and United States military vehicles, must be equipped with flaps behind the rearmost wheels, with ground clearance not more than 9 inches. Bottom unloading vehicles (i.e. belly-dumps) also require a center flap with a clearance not exceeding 6 inches.

BRAKES: Every motor vehicle must be equipped with brakes adequate to stop and hold such vehicle, including two separate means of applying the brakes, on at least two wheels. In general, trailers and semi-trailers with a gross weight of 3,000 pounds or more must be equipped with brakes adequate to control the movement of and to stop and hold the trailer or semi-trailer. Trailers or semi-trailers which are required to have brakes must also be equipped with a breakaway system which allows the brakes to activate automatically should the trailer or semi-trailer become detached from the towing unit.

EXCEPTIONS: Vehicles having three or more axles manufactured prior to 7/1/1988 are not required to be equipped with brakes on the front axle if the brakes on the other wheels are adequate to meet performance standards prescribed by state law. (Pursuant to federal rules, this exception does not apply to vehicles manufactured after 7/24/1980 which are engaged in interstate commerce) A temporary auxiliary axle attached to a motor vehicle during the period of road restrictions for the purpose of relieving weight

on another axle need not be equipped with brakes if the combined weight of the temporary auxiliary axle and the axle to be relieved does not exceed 18,000 pounds.

HEADLIGHTS must be dimmed when within 1,000 feet of an oncoming vehicle and within 200 feet when following another vehicle. Lighted lamps are required during the period of sunset to sunrise; any time it is raining, snowing, sleeting, or hailing; and at any time when visibility is impaired due to such things as weather, fog, or smoke.

CLEARANCE LAMPS are required on every vehicle 80 inches or more in width unladen or with load. Two are mounted in front on opposite sides at least 24 inches above the headlight centers and not more than 6 inches from the outer edge, and two are similarly mounted on the rear. The forward lamps must be amber in color and the rear lamps must be red. **(2D)**

IDENTIFICATION LAMPS are required on the front of truck-tractors and rear of semi-trailers and trailers 80 inches or more in width and both the front and rear of trucks and buses 80 inches or more in width. **(2E)**

LICENSE PLATE must be lighted and visible from a distance of 50 feet to the rear. The license plate must be kept clean, legible, and unobstructed. Covering the license plate with any material, including clear or colorless materials that affect the plate's visibility or reflectivity is prohibited. **(2B)**

TAIL LAMPS: Two red tail lamps visible from a distance of 500 feet are required. They must be mounted at the same level (between 15 and 72 inches from the ground) and spaced as widely as practicable. **(2A)**

FLASHING LIGHTS are prohibited, except on an authorized emergency vehicle, school bus, road maintenance equipment, farm tractors, self-propelled farm equipment or any vehicle as a means of indicating a right or left turn or the presence of a vehicular traffic hazard. All flashing warning lights must be the four-way flasher type unless otherwise authorized by law.

STOP LAMPS: Two red stop lamps visible from a distance of 500 feet are required. They must be mounted at the same level (between 15 and 72 inches from the ground) and spaced as widely as practicable. **(2C)**

TURN SIGNALS: Two red or amber lamps visible from a distance of 500 feet are required. They must be mounted at the same level (between 15 and 83 inches from the ground) and spaced as widely as practicable.

MARKER LAMPS are required on vehicles or combinations exceeding 30 feet in length; one on each side near the front of the vehicle and one each side near the rear, not less than 24 inches above the roadway; amber in the front and red in the rear, each visible for a distance of 500 feet to the side. Clearance lamps that are visible at 90 degree angles to the right and left sides, respectively, may also serve as marker lamps, provided an additional amber marker lamp is displayed approximately midway between the front and rear clearance lamps.

REFLECTORS: Two red reflectors are required on the rear of the vehicle, not less than 20 nor more than 60 inches above the roadway and spaced as far apart as practicable. Reflectors may be incorporated into the rear lamps of a vehicle. **(2A)**

